

ofifran

TECHNICAL CATALOGUE GALLERY 2020

TABLETOP CONFIGURATION

EXECUTIVE



1045 x 750 (h)



2085 x 1045

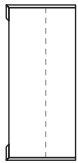

2285 x 1045

PRESIDENTIAL



2265 x 750 (h)

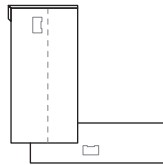

2085 x 2265

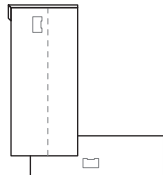

2285 x 2265

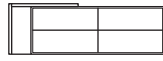

2265 x 750 (h)

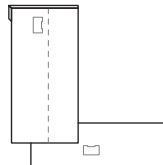

2085 x 2265

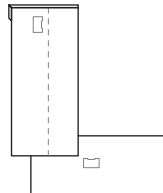

2285 x 2265

MEETING



1200 x 750 (h)



2400 x 1200



3000 x 1200



1300 x 1300

BOARDROOM

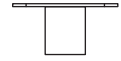

1600 x 750 (h)

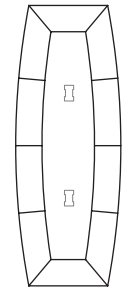

3200 x 1600

TECHNICAL DETAILS



1 The table top is made of 40 mm 630 kg/m³ MDF fiber board thickness and natural American walnut veneer.

2 With optional natural grain leather insert and 2 mm American walnut edge.

3 Legs are made in a 90° miter with folding on a 40 mm MDF board thick veneered with natural veneer and 2 mm American walnut wood edge with soforming modeling. These legs have a trim to hide the cables rise.



4 The table has a cable tray made of MDF board 20 mm thick and natural veneer with 0.5 mm American walnut wood edge.

5 Cable access included with a hinged wooden cable flip top same finish as the table.

6 Modesty panel is made of 40 mm thick MDF board veneered with American walnut veneer and with 2 mm wood edge in American walnut.

- Matte finish - open grain:

The furniture is made with 80 grs/m² stain in 3 finishes: Natural walnut, espresso, Italian walnut 150 grs/m² acrylic base with hardener and matte acrylic hardened open grain finish

- Semi-gloss finish - closed grain

The furniture is made with 80 grs/m² stain in 3 finishes: Natural walnut, espresso, Italian walnut on two-pass unalterable layer, polyacrylic primer two layers of 150 grs/m² with hardener and finished with semi-gloss polyurethane lacquer hardened closed grain. Matte lacquered finishes:

- The furniture is made with a layer of 150 grs/m² white polyurethane, one layer of transparent polyacrylic and lastly a hardened color is applied to the thirteen catalog finishes.



TECHNICAL DETAILS - EXECUTIVE TABLE

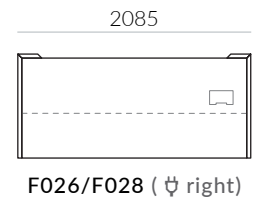
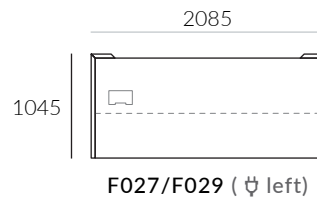
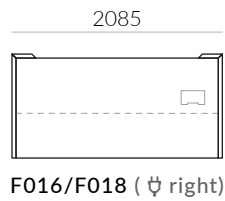
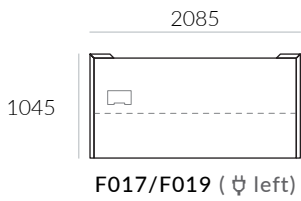

- 1 The table top is made of 40 mm 630 kg/m³ MDF fiber board thickness and natural American walnut veneer.
- 2 With optional natural grain leather insert and 2 mm American walnut edge.
- 3 Legs are made in a 90° miter with folding on a 40 mm MDF board thick veneered with natural veneer and 2 mm American walnut wood edge with soforming modeling. These legs have a trim to hide the cables rise.
- 4 The table has a cable tray made of MDF board 20 mm thick and natural veneer with 0.5 mm American walnut wood edge.
- 5 Cable access included with a hinged wooden cable flip top in same finish as the table.
- 6 Optional full modesty panel is made of 40 mm thick MDF board veneered with American walnut veneer and with 2 mm wood edge in American walnut.
- 7 Two available sizes

TECHNICAL DETAILS - EXTENSIONS

Made of 40 mm thick MDF board and natural American walnut veneer. Legs made in a 90 ° miter with folding in 40 mm thick MDF board veneered with natural veneer and 2 mm American walnut wood edge with soforming modeling. With optional natural grain leather insert and 2 mm American walnut edge.

Available in two sizes and in right and left options.

Height 750 mm.



Examples of composition and dimensions

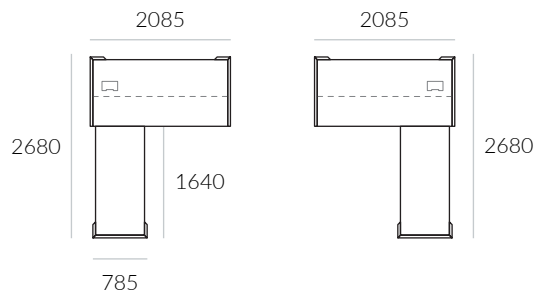
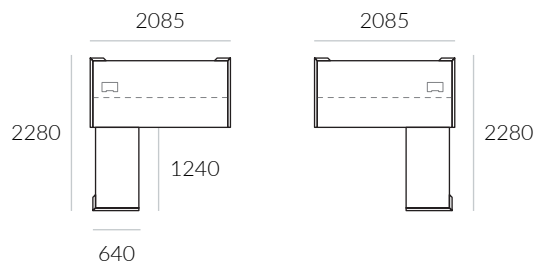

TECHNICAL DETAILS - PRESIDENTIAL TABLE WITH 600 MM DEPTH SIDEBOARD

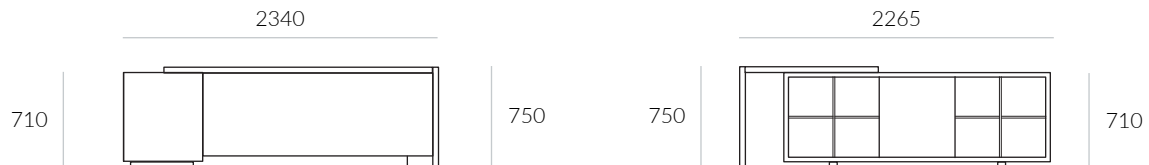
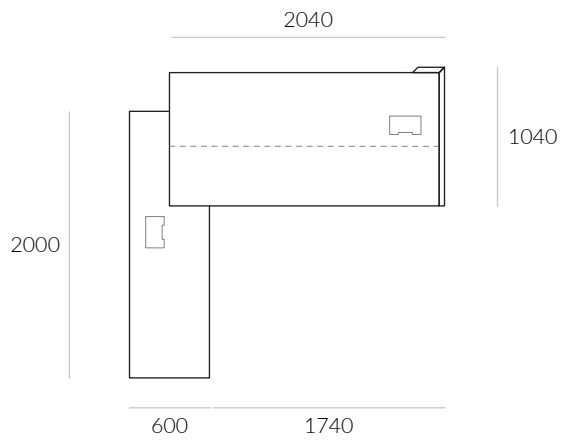

Ref F013

- 1 The table top is made of 40 mm 630 kg/m³ MDF fiber board thickness and natural American walnut veneer.
- 2 With optional natural grain leather insert and 2 mm American walnut edge.
- 3 Legs are made in a 90° miter with folding on a 40 mm MDF board thick veneered with natural veneer and 2 mm American walnut wood edge with soforming modeling. These legs have a trim to hide the cables rise.
- 4 The table has a double cable tray made of MDF board 20 mm thick and natural veneer with 0.5 mm American walnut wood edge.
- 5 Cable access included with a hinged wooden cable flip top in same finish as the table.
- 6 Full modesty panel is made of 40 mm thick MDF board veneered with American walnut veneer and with 2 mm wood edge in American walnut.
- 7 Pedestal integrated in sideboard, made of 20 mm thick chipboard and natural American walnut veneer. The edges are veneered with 0.5 mm and 2 mm American walnut edge respectively. Drawers made in beech wood. Stainless steel self-extracting metal guides and epoxy paint finish. Soft closing.
- 8 Shelves and interior sides of the sideboard always lacquered to match the color of the leather insert.
- 9 The table has a cable tray made of MDF board 20 mm thick and natural veneer with 0.5 mm American walnut wood edge.
- 10 Two available sizes
Optional back panel for sideboard.

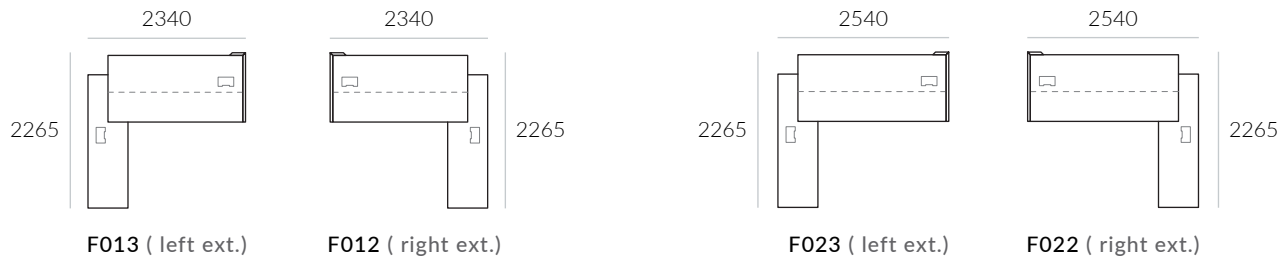

TECHNICAL DETAILS - PRESIDENTIAL TABLE WITH 820 MM DEPTH SIDEBOARD

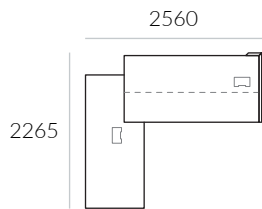

F015 (left ext.)

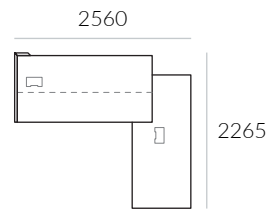

F014 (right ext.)

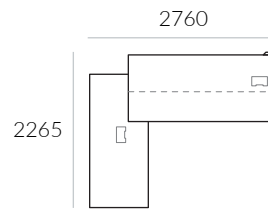

F025 (left ext.)

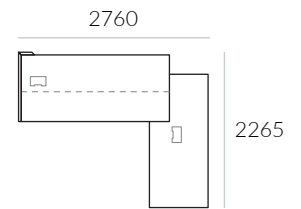

F024 (right ext.)

- 1 The table top is made of 40 mm 630 kg/m³ MDF fiber board thickness and natural American walnut veneer.
- 2 With optional natural grain leather insert and 2 mm American walnut edge.
- 3 Legs are made in a 90° miter with folding on a 40 mm MDF board thick veneered with natural veneer and 2 mm American walnut wood edge with soforming modeling. These legs have a trim to hide the cables rise.
- 4 Cable access included with a hinged wooden cable flip top in same finish as the table.
- 5 The table has a double cable tray made of MDF board 20 mm thick and natural veneer with 0.5 mm American walnut wood edge.
- 6 Full modesty panel is made of 40 mm thick MDF board veneered with American walnut veneer and with 2 mm wood edge in American walnut.
- 7 Pedestal integrated in sideboard, made of 20 mm thick chipboard and natural American walnut veneer. The edges are veneered with 0.5 mm and 2 mm American walnut edge respectively. Drawers made in beech wood. Stainless steel self-extracting metal guides and epoxy paint finish. Soft closing.
- 8 Shelves and interior sides of the sideboard always lacquered to match the color of the leather insert.
- 9 External shelves of the sideboard in 20 mm thick chipboard and natural American walnut veneer. Veneered edges with American walnut wood edge.
- 10 The table has a cable tray made of MDF board 20 mm thick and natural veneer with 0.5 mm American walnut wood edge.
- 11 Two available sizes.

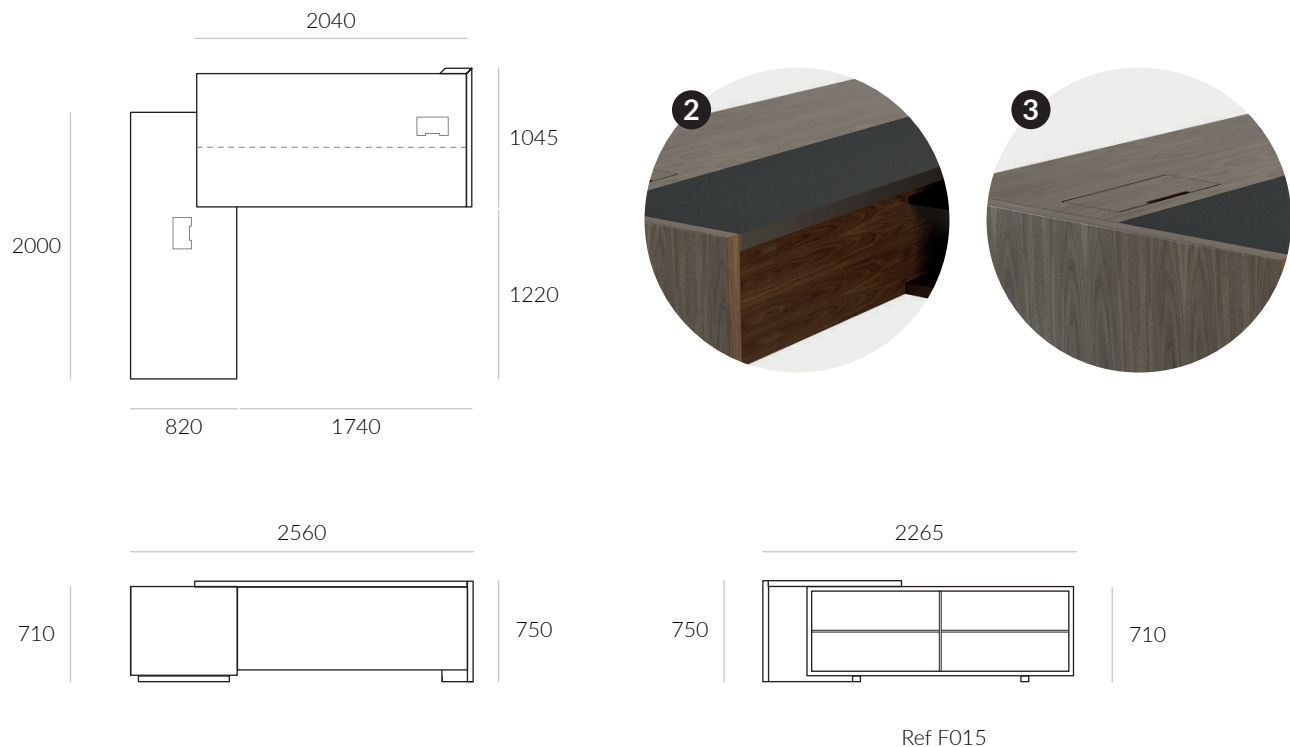

TECHNICAL DETAILS - MEETING TABLES

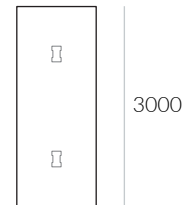
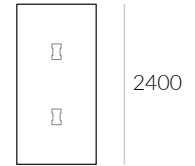
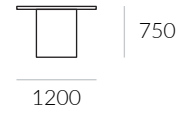

- 1 The table top is made of 40 mm 630 kg/m³ MDF fiber board thickness and natural American walnut veneer.
- 2 Legs are made in a 90° miter with folding on a 40 mm MDF board thick veneered with natural veneer and 2 mm American walnut wood edge with soforming modeling.
- 3 Cable access included with a hinged wooden cable flip top in same finish as the table.
- 4 The table has a cable tray made of MDF board 20 mm thick and natural veneer with 0.5 mm American walnut wood edge.
- 5 Three available sizes and shapes



TECHNICAL DETAILS - BOARDROOM TABLE

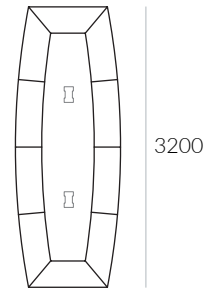
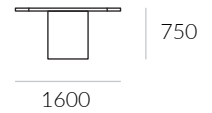

- 1 The table top is made of 40 mm 630 kg/m³ MDF fiber board thickness and natural American walnut veneer.
- 2 With optional natural grain leather insert and 2 mm American walnut edge.
- 3 Legs are made in a 90° miter with folding on a 40 mm MDF board thick veneered with natural veneer and 2 mm American walnut wood edge with soforming modeling.
- 4 The table has a cable tray made of MDF board 20 mm thick and natural veneer with 0.5 mm American walnut wood edge.
- 5 Cable access included with a hinged wooden cable flip top in same finish as the table.
- 6 Customizable for projects.

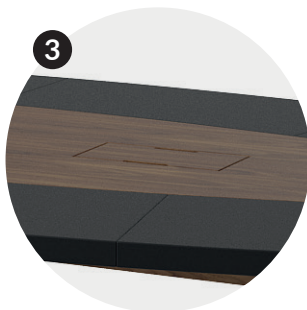

TECHNICAL DETAILS - STORAGE - SIDEBOARD 600 MM DEPTH



- 1 Body made of 40 mm thick MDF board and natural American walnut veneer, the edges are veneered with edge 2 mm American walnut wood.
- 2 Pedestal carcass made of 20 mm thick chipboard.
- 3 Fronts made of 19 mm thick MDF board and natural American walnut veneer with 2 mm wooden edge.
- 4 Drawers made of beech wood and made with dovetail joint. Stainless steel soft closing metal guides epoxy painted.
- 5 The shelves and internal partitions can be lacquered or in the same color as the furniture, at the customer's choice.
- 6 Optional back panel available for auxiliary furniture.

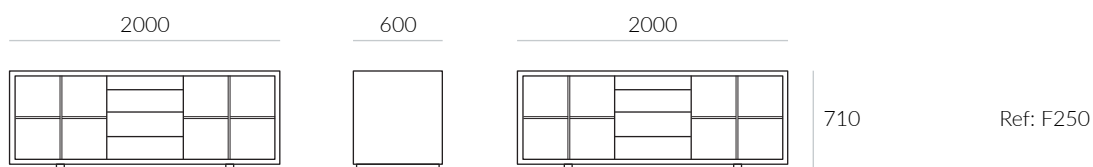

TECHNICAL DETAILS - STORAGE - SIDEBOARD 820 MM DEPTH



- 1 Body made of 40 mm thick MDF board and natural American walnut veneer, the edges are veneered with edge 2 mm American walnut wood.
- 2 Pedestal carcase made of 20 mm thick chipboard.
- 3 Fronts made of 19 mm thick MDF board and natural American walnut veneer with 2 mm wooden edge.
- 4 Drawers made of beech wood and made with dovetail joint. Stainless steel Soft closing metal guides epoxy painted.
- 5 The shelves and internal partitions can be lacquered or in the same color as the furniture, at the customer's choice.



TECHNICAL DETAILS - STORAGE - CREDENZA



- 1 Bookcase body made of 20 mm thick chipboard in natural American walnut veneer and 0.5 mm wooden edge.
- 2 Doors made with 20 mm thick MDF board in 2 mm thick natural American walnut veneer.
- 3 Bookcase top made of 40 mm thick chipboard in natural American walnut veneer and 2 mm wooden edge.
- 4 Sides made in 90 ° miter with folding on 40 mm thick MDF board veneered with natural veneer and wooden edge of 2 mm American walnut with soforming modeling.
- 5 Back panel made of chipboard 20 mm thick in natural American walnut veneer 0.5 mm thick.
- 6 Each of the components can be in a wooden or lacquered finish, at the customer's choice, generating a large number of combinations.

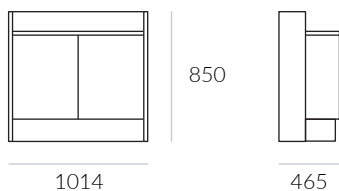

TECHNICAL DETAILS - STORAGE - BOOKSHELF AND CREDENZA



- 1 Bookcase body made of 20 mm thick chipboard in natural American walnut veneer and 0.5 mm wooden edge.
- 2 Doors made with 20 mm thick MDF board in 2 mm thick natural American walnut veneer.
- 3 Bookcase top made of 40 mm thick chipboard in natural American walnut veneer and 2 mm wooden edge.
- 4 Sides made in 90 ° miter with folding on 40 mm thick MDF board veneered with natural veneer and wooden edge of 2 mm American walnut with soforming modeling.
- 5 Back panel made of chipboard 20 mm thick in natural American walnut veneer 0.5 mm thick.
- 6 Shelves made with 40 mm thick chipboard in natural American walnut veneer and 2 mm wooden edge.
- 7 Each of the components can be in a wooden or lacquered finish, at the customer's choice, generating a large number of combinations

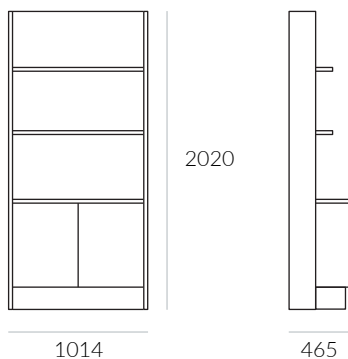

TECHNICAL DETAILS - STORAGE - PEDESTAL WITH WOODEN INTERIOR



- 1 Pedestal Body made of 40 mm thick MDF board and natural American walnut veneer, edges are veneered with edge 2 mm American walnut wood.
- 2 Fronts made of 19 mm thick MDF board and natural American walnut veneer with 2 mm wooden edge.
- 3 Drawers made of beech wood and made with dovetail joint. Stainless steel Soft closing metal guides epoxy painted.

TECHNICAL DETAILS - STORAGE - PEDESTAL WITH METAL INTERIOR

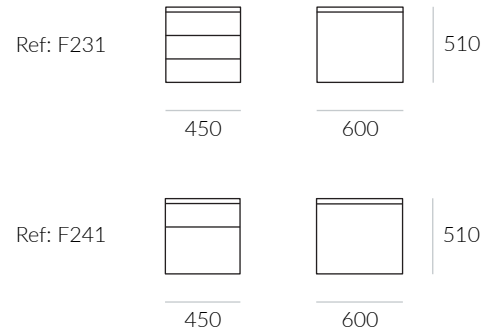
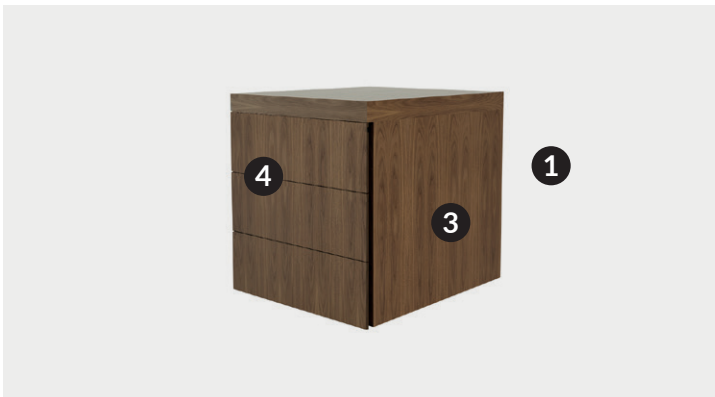

- 1 Drawers carcase is made of laminated sheet steel with plasma welding and epoxy paint finish.
- 2 Metal drawers with hidden opening guides $\frac{3}{4}$ and brake system. Provided with a central locking lock and anti-tilt system.
- 3 Chest of drawers made with AG board 20 mm thick, with natural American Walnut veneer. Top made of 40 mm thick MDF and natural American walnut veneer. All edges are veneered with walnut edge American of 0.5 mm and 2 mm respectively.
- 4 Pedestal fronts made of 20 mm thick MDF board and natural American walnut veneer with 2 mm wooden edge.

TECHNICAL DETAILS - COUNTER



- 1 Counter work top made of 630 kg/m³ fiberboard 40 mm thick MDF and natural American walnut veneer with 2 mm American walnut edge
- 2 Table legs made in 90 ° miter with folding in 40 mm thick MDF board veneered with natural veneer and edge made of 2 mm American walnut wood with soforming modeling.
- 3 The work surface has a charging unit and plug
- 4 Cable tray made of 20 mm thick MDF board and natural veneer and with 0.5 mm wood edge in American walnut.
- 5 Front made with 20 mm thick MDF board veneered with natural veneer and with 2 mm American walnut wood edge, completed with a counter top made of 25 mm thick MDF.
- 6 Coated with 6 mm thick Neolith sintered porcelain, in two color options.
- 7 Indirect lighting installation with LEDs.

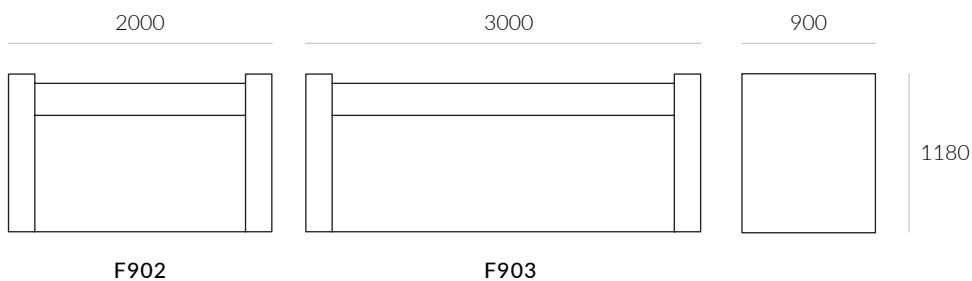

FINISHINGS

LEATHER

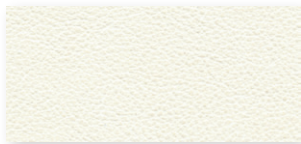

WHITE
PI07

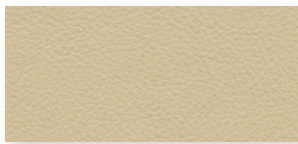

IVORY
PI04



CAMEL
PI12



PUMPKIN
PI16

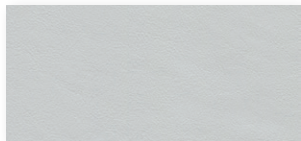

ICE
PI15



GREY
PI11

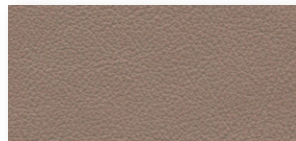

STONE
PI09

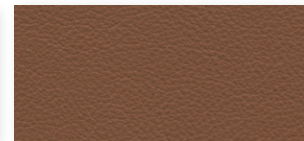

LIGHT BROWN
PI02

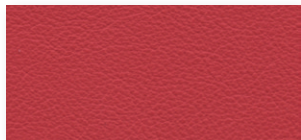

RED
PI05



GREEN
PI00

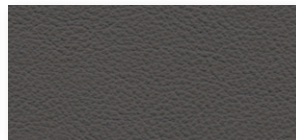

ANTHRACITE
PI08

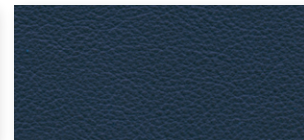

BLUE
PI03

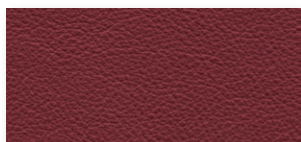

BORDEAUX
PI13

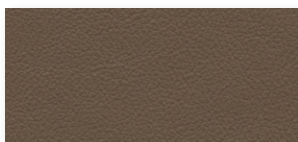

UMBER
PI17

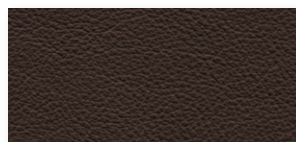

DARK BROWN
PI06

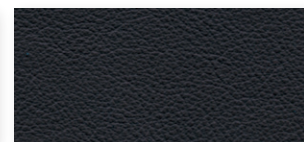

BLACK
PI01

PORCELAIN (Counters only)



MONT BLANC
Q64

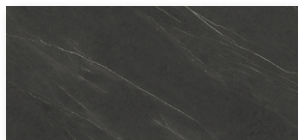

PIETRA GREY
Q63

WOOD

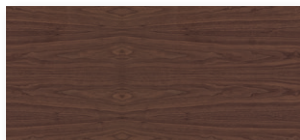

ITALIAN WALNUT
NI

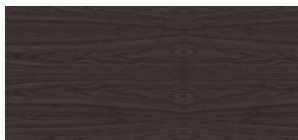

ESPRESSO
EM

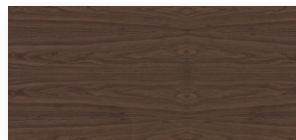

NATURAL WALNUT
NM

LACQUERED

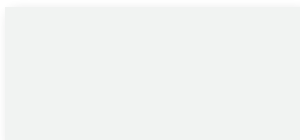

WHITE
L07



IVORY
L04



CAMEL
L12



PUMPKIN
L16

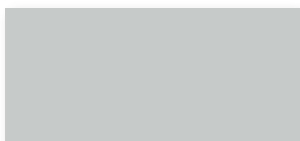

ICE
L15



GREY
L11



STONE
L09



LIGHT BROWN
L02



RED
L05



GREEN
L00



ANTHRACITE
L08



BLUE
L03

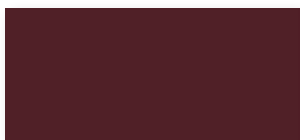

BORDEAUX
L13



UMBER
L17

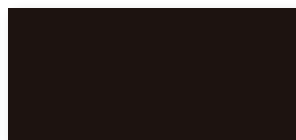

DARK BROWN
L06



BLACK
L01

CODIFICATION

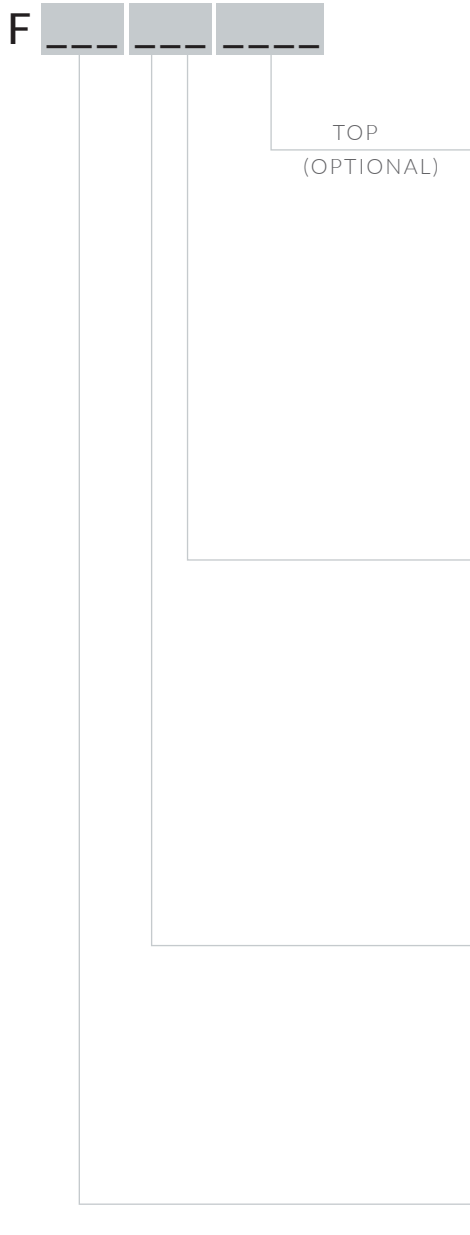

TOP
(OPTIONAL)

LEATHER



LACQUERED



WOOD

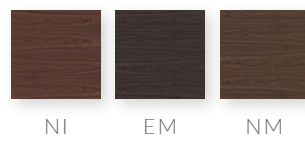

- 1 Matt finishings - open grain
- 2 Semi-gloss finishings - closed grain

REFERENCE



F 016 NM1 PI01



F 022 NM1 P101*

* The shelves and the inner side of the auxiliary furniture will be in the same lacquered color as the leather.

DIRECTIONAL TABLES

L 2085 A 1045 H 750 / 5 Pkg, 139 Kg, 0,976 m³

F017/F019 (ħ left) F016/F018 (ħ right)

Directional table with wooden flip top cable access, with optional leather insert and optional full modesty panel.

Includes a wooden cable management tray under the top.

	DIMENSIONS (MM.)	CODE	PKG	KG	M ³
	2085 x 1045 x 750	F016 (ħ right) F017 (ħ left)	5	139,0	0,976
LEATHER INSET					
	2085 x 1045 x 750	F016 (ħ right) F017 (ħ left)	5	139,0	0,976
MODESTY PANEL					
	2085 x 1045 x 750	F018 (ħ right) F019 (ħ left)	5	166,0	1,098
MODESTY PANEL + LEATHER INSET					
	2085 x 1045 x 750	F018 (ħ right) F019 (ħ left)	5	166,0	1,098

L 2285 A 1045 H 750 / 5 Pkg, 134 Kg, 1,138 m³

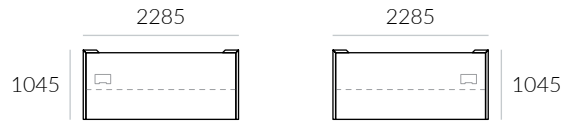

F027/F029 (Ľ left)

F026/F028 (Ľ right)

Directional table with wooden flip top cable access, with optional leather inset and optional full modesty panel.

Includes a wooden cable management tray under the top.

	DIMENSIONS (MM.)	CODE	PKG	KG	M ³
	2285 x 1045 x 750	F026 (Ľ right)	5	143,0	0,998
		F027 (Ľ left)			
LEATHER INSET					
	2285 x 1045 x 750	F026 (Ľ right)	5	143,0	0,998
		F027 (Ľ left)			
MODESTY PANEL					
	2285 x 1045 x 750	F028 (Ľ right)	5	183,5	1,138
		F029 (Ľ left)			
MODESTY PANEL + LEATHER INSET					
	2285 x 1045 x 750	F028 (Ľ right)	5	183,5	1,138
		F029 (Ľ left)			

PRESIDENTIAL TABLES

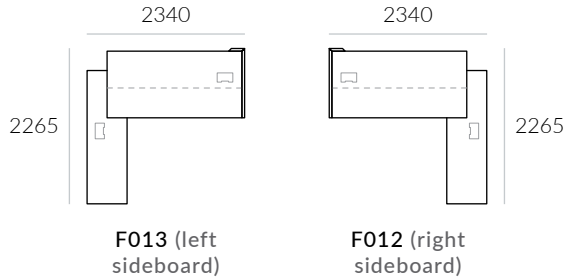

L 2340 A 2265 H 750 / 9 Pkg, 302 Kg, 1,334 m³

Presidential table with full modesty panel and 600 mm. deep sideboard with 3 drawer pedestal and shelves. Double wooden flip top cable access and optional leather insert. Includes a wooden cable management tray under the top.

DIMENSIONS (MM.)

CODE

PKG

KG

M³



2340 x 2265 x 750

☐ right (sideboard)
+
☐ left (table)

F012

F013

☐ left (sideboard)
+
☐ right (table)

9 302,0 1,334

LEATHER INSET



2340 x 2265 x 750

☐ right (sideboard)
+
☐ left (table)

F012

F013

☐ left (sideboard)
+
☐ right (table)

9 302,0 1,334

OPTIONAL SET OF BACK PANEL FOR 600 MM DEPTH SIDEBOARD

Set of back panel for sideboard

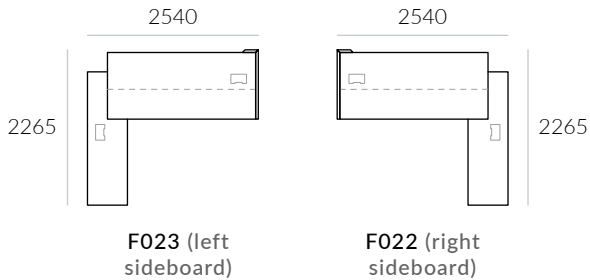

F251

1 13,0 0,053



L 2540 A 2265 H 750 / 9 Pkg, 309,5 Kg, 1,535 m³

Presidential table with full modesty panel and 600 mm. deep sideboard with 3 drawer pedestal and shelves. Double wooden flip top cable access and optional leather insert. Includes a wooden cable management tray under the top.

	DIMENSIONS (MM.)	CODE	PKG	KG	M ³
	2540 x 2265 x 750	☺ right (sideboard) + ☺ left (table) F022	9	309,5	1,535
		F023 ☺ left (sideboard) + ☺ right (table)			
LEATHER INSET 	2540 x 2265 x 750	☺ right (sideboard) + ☺ left (table) F022	9	309,5	1,535
		F023 ☺ left (sideboard) + ☺ right (table)			

OPTIONAL SET OF BACK PANEL FOR 600 MM DEPTH SIDEBOARD

Set of back panel for sideboard	F251	1	13,0	0,053
---------------------------------	-------------	---	------	-------

PRESIDENTIAL TABLES

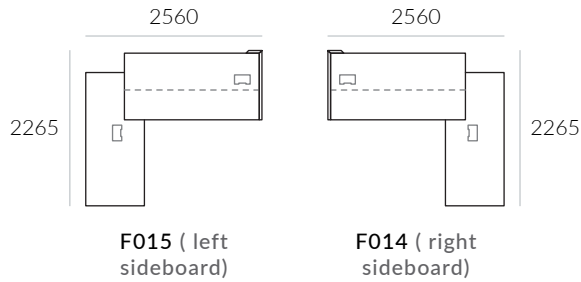

L 2560 A 2265 H 750 / 10 Pkg, 340 Kg, 1,479 m³

Presidential table with full modesty panel and 820 mm. deep sideboard with 3 drawer pedestal and shelves. Double wooden flip top cable access and optional leather insert. Includes a wooden cable management tray under the top.

DIMENSIONS (MM.)

CODE

PKG

KG

M³



2560 x 2265 x 750

☞ right (sideboard)
+
☞ left (table)

F014

F015

10 340,0 1,479



☞ left (sideboard)
+
☞ right (table)



2560 x 2265 x 750

☞ right (sideboard)
+
☞ left (table)

F014

F015

10 340,0 1,479



☞ left (sideboard)
+
☞ right (table)

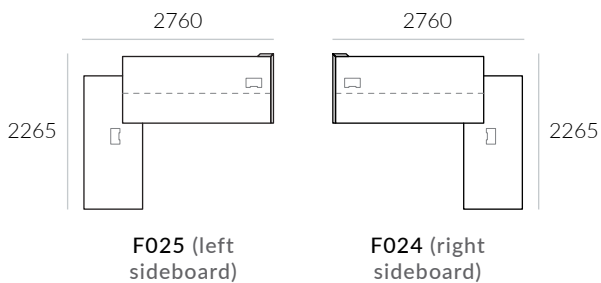

L 2760 A 2265 H 750 / 10 Pkg, 363,5 Kg, 1,694 m³

Presidential table with full modesty panel and 820 mm. deep sideboard with 3 drawer pedestal and shelves. Double wooden flip top cable access and optional leather insert. Includes a wooden cable management tray under the top.

DIMENSIONS (MM.)

CODE

PKG

KG

M³



2760 x 2265 x 750

☺ right (sideboard)

+

☺ left (table)

F024

F025

10 363,5 1,694



2760 x 2265 x 750

☺ left (sideboard)

+

☺ right (table)

F024

F025

10 363,5 1,694



2760 x 2265 x 750

☺ right (sideboard)

+

☺ left (table)

F024

F025

10 363,5 1,694



2760 x 2265 x 750

☺ left (sideboard)







+







☺ right (table)

F024

F025

10 363,5 1,694

	DIMENSIONS (MM.)	CODE	PKG	KG	M ³
SIDE TABLES AND EXTENSIONS					
	1285 x 640 x 750	F110	4	62,5	0,350
	1640 x 785 x 750	F130	4	46,4	0,270
	1240 x 640 x 750 right	F100	4	46,5	0,225
	1240 x 640 x 750 left	F101	4	46,5	0,225
LEATHER EXTENSIONS					
	1240 x 640 x 750 right	F100	4	46,5	0,225
	1240 x 640 x 750 left	F101	4	46,5	0,225

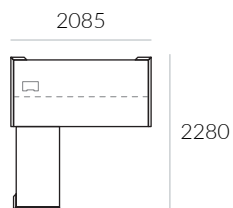

	DIMENSIONS (MM.)	CODE	PKG	KG	M ³
DRAWER UNIT WITH WHEELS AND LOCK. WOOD INTERIOR					
	450 x 600 x 660 laquered front	F230	1	36,4	0,250
4 drawer					
	450 x 600 x 660 laquered front	F240	1	46,4	0,210
2 drawer + 1 file drawer					
DRAWER UNIT WITH WHEELS AND LOCK. METAL INTERIOR					
	450 x 565 x 510	F231	1	35,0	0,146
3 drawer					
	450 x 565 x 510	F241	1	35,0	0,146
1 drawer + 1 file drawer					
COFFEE TABLES					
	685 x 680 x 450	F450	4	54,5	0,197
	1285 x 680 x 450	F460	4	70,5	0,254

COMPOSITION EXAMPLES



L 2085 A 2280 H 750 / 9 Pkg, 212,5 Kg, 1,323 m³

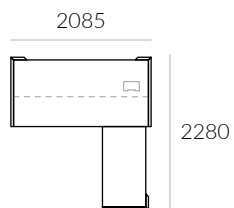

Directional desk with full modesty panel and leather insert with left extension leather top. Wooden flip top cable access in left side of table

	DIMENSIONS (MM.)	CODE	PKG	KG	M ³
	2085 x 1045 x 750	F018	5	166,0	1,098
	1240 x 640 x 750	F100	4	46,5	0,225
TOTAL:			9	212,5	1,323



L 2085 A 2280 H 750 / 9 Pkg, 185,5 Kg, 1,201 m³

Directional desk with full modesty panel and leather insert with left extension leather top. Wooden flip top cable access in left side of table

	DIMENSIONS (MM.)	CODE	PKG	KG	M ³
	2085 x 1045 x 750	F017	5	139,0	0,976
	1240 x 640 x 750	F101	4	46,5	0,225
TOTAL:			9	185,5	1,201

MEETING TABLES

L 2400 A 1200 H 750 / 4 Pkg, 146 Kg, 0,500 m³

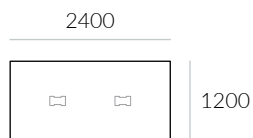

Meeting table supplied with two wooden cable access in the top made by a wooden flip top with hinges.

F170 (↕ both sides)

DIMENSIONS (MM.)

CODE

PKG

KG

M³

RECTANGULAR MEETING TABLES

OPEN GRAIN



2400 x 1200 x 750

F170
(↕ both sides)

4 146,0 0,500

LACQUERED/ CLOSED
GRAIN

2400 x 1200 x 750

F170
(↕ both sides)

4 146,0 0,500

L 3000 A 1200 H 750 / 4 Pkg, 179 Kg, 0,700 m³



Meeting table supplied with two wooden cable access in the top made by a wooden flip top with hinges.

F180 (̣ both sides)

DIMENSIONS (MM.)

CODE

PKG

KG

M³

RECTANGULAR MEETING TABLES

OPEN GRAIN



3000 x 1200 x 750

F180
(̣ both sides)

4 179,0 0,700

LACQUERED/ CLOSED
GRAIN



3000 x 1200 x 750

F180
(̣ both sides)

4 179,0 0,700

MEETING TABLES

Ø 1300 H 750 / 3 Pkg, 63 Kg, 0,500 m³

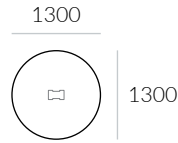

F150 (⚡ central)

Round meeting table supplied with two wooden cable access in the top made by a wooden flip top with hinges, and wooden cable management tray under the top.

	DIMENSIONS (MM.)	CODE	PKG	KG	M³
--	------------------	------	-----	----	----

ROUND MEETING TABLES

OPEN GRAIN



Ø 1300 x 750

F150
(⚡ central)

3 63,0 0,500

LACQUERED/ CLOSED GRAIN



Ø 1300 x 750

F150
(⚡ central)

3 63,0 0,500

ANCILLARY FOR GROMMETS



only black

300 x 54 x 54
exempt electrification

AUX7003
2TSN+1USB
charge 5V/2A+RJ45

1 0,5 0,001

CABLES AND ANCILLARY



2 metros power cable - male schuko
socket/female rapid connector

PAS7022

1 0,1 0,001

3 metros power cable - male schuko
socket/female rapid connector

PAS7023

1 0,1 0,001



Vertebra technical cable organisation

PAS7020

1 0,1 1,0

Our electrifications are referenced with the European plug (type C). For any other country, consult the factory.

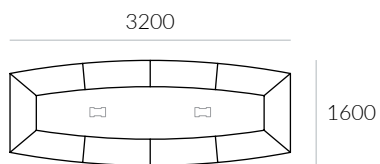

F140 (↕ both sides)

L 3200 A 1600 H 750 / 5 Pkg, 200 Kg, 1,200 m³

Boardroom table supplied with two wooden cable access in the top made by a wooden flip top with hinges. Leather insert. The desk is supplied with a wooden cable management tray under the top.

DIMENSIONS (MM.)	CODE	PKG	KG	M ³
------------------	------	-----	----	----------------

BOARDROOM TABLES

LEATHER



3200 x 1600 x 750

F140
(↕ both sides)

5 200,0 1,200

ECOLEATHER / LACQUERED



3200 x 1600 x 750

F140
(↕ both sides)

5 200,0 1,200



According to project

FP9991

-

	DIMENSIONS (MM.)	CODE	PKG	KG	M ³
--	------------------	------	-----	----	----------------

AUXILIARY SIDEBOARD 600 MM DEPTH

W/O BACKPANEL



2000 x 600 x 710

F250

6 159,0 0,582

WITH BACKPANEL



2000 x 600 x 710

F250 + F251

7 172,0 0,635

AUXILIARY SIDEBOARD 820 MM DEPTH



2000 x 820 x 710

F260

7 205,0 0,700



* The back of the drawer will always be in the same finish as the furniture

DIMENSIONS (MM.)

CODE

PKG

KG

M³

CABINET WITH UPPER DOORS



1945 x 465 x 2020

F384

13 251,0 0,060













2880 x 465 x 2020

F386

16 345,0 1,400

FREEPORT COLLECTION
BOOKCASE COMPONENTS





	DIMENSIONS (MM.)	CODE	PKG	KG	M³
CABINET BODY					
	930 x 400 x 550	G301	1	33,0	0,110
SET OF LOW DOORS WITH NO LOCK					
	930 x 20 x 547 without lock	G335S	1	9,0	0,030
SET OF LOW DOORS WITH LOCK					
	930 x 20 x 547 with lock	G335C	1	9,0	0,030
BOOKCASE TOPS					
	930 x 425 x 41	G602	1	9,6	0,052
	1860 x 425 x 41	G604	1	22,0	0,100
	2790 x 425 x 41	G606	1	27,2	0,160

	DIMENSIONS (MM.)	CODE	PKG	KG	M ³
BACK PANEL AND SIDES FOR LOW CABINET					
	1014 x 465 x 850	F512	1	31,4	0,310
	1945 x 465 x 850	F514	2	56,0	0,480
	2880 x 465 x 850	F516	3	80,4	0,610
BACK PANEL AND SIDES FOR HIGH CABINET. 2 SHELVES INCLUDED					
	1015 x 445 x 2020	F532	3	58,0	0,310
	1945 x 445 x 2020	F534	4	104,0	0,460
	2880 x 465 x 2020	F536	5	144,2	0,680

COMPOSITION EXAMPLE

**D 1015 W 465 H 850/**4 Pkg, 77,1 Kg, 0,299 m³

One body sideboard with two lacquered doors and low back panel in open grain.





	DIMENSIONS (MM.)	CODE	UNITS	PKG	KG	M ³	
	930 x 400 x 550 open grain bookcase	G301EM1	x 1	1	33,0	0,110	
	930 x 20 x 547 lacquered doors without lock	G335SL09	x 1	1	9,0	0,030	
	930 x 425 x 41 open grain bookcase top	G602EM1	x 1	1	9,6	0,052	
	1015 x 465 x 850 open grain back panel	F512EM1	x 1	1	25,5	0,037	
				TOTAL:	4	77,1	0,229



D 1015 W 465 H 2020/

6 Pkg, 132,0 Kg, 0,802 m³

One body sideboard with two lacquered doors with lock and high back panel in open grain, plus two decorative shelves.





	DIMENSIONS (MM.)	CODE	UNITS	PKG	KG	M ³
	930 x 400 x 550 open grain bookcase	G301EM1	x 1	1	33,0	0,110
	930 x 20 x 547 lacquered doors with lock	G335CL09	x 1	1	9,0	0,030
	930 x 425 x 41 open grain bookcase top	G602EM1	x 1	1	9,6	0,052
	1015 x 465 x 2020 open grain back panel	F532EM1L09	x 1	3	80,4	0,610
TOTAL:				6	132,0	0,802

Decorative shelves. Do not place more than 20 Kg in each shelf. For heavier loads the back panel should be reinforced with additional ironworks. Consult with your sales agent.

COMPOSITION EXAMPLE

**L 1945 A 465 H 850/**7 Pkg, 162 Kg, 0,557 m³

Two body sideboard with two pairs of lacquered doors and low back panel in open grain. Lacquered bookcase top.





	DIMENSIONS (MM.)	CODE	UNITS	PKG	KG	M ³
	930 x 400 x 550 open grain bookcase	G301EM1	x 2	1	33,0	0,110
	930 x 20 x 547 lacquered doors without lock	G335SL01	x 2	1	9,0	0,030
	1860 x 425 x 41 lacquered bookcase top	G604L01	x 1	1	22,0	0,100
	1945 x 465 x 850 open grain back panel	F514EM1	x 1	2	56,0	0,177
TOTAL:				7	162,0	0,557



L 1945 A 465 H 2020/

7 Pkg, 162 Kg, 0,557 m³

Two body sideboard with two pairs of lacquered doors and high back panel in open grain, plus two decorative shelves. Lacquered bookcase top.

	DIMENSIONS (MM.)	CODE	UNITS	PKG	KG	M³
	930 x 400 x 550 open grain bookcase	G301EM1	x 2	1	33,0	0,110
				2	66,0	0,220
	930 x 20 x 547 lacquered doors without lock	G335SL01	x 2	1	9,0	0,030
				2	18,0	0,060
	1860 x 425 x 41 lacquered bookcase top	G604L01	x 1	1	22,0	0,100
	1945 x 465 x 2020 open grain high back panel	F534EM1L01	x 1	5	226,2	1,180
TOTAL:				10	332,2	1,560

Decorative shelves. Do not place more than 35 Kg in each shelf. For heavier loads the back panel should be reinforced with additional ironworks. Consult with your sales agent.

COMPOSITION EXAMPLE

**L 2880 A 465 H 850/**

10 Pkg, 235,7 Kg, 0,802 m³





Three body sideboard with three pairs of lacquered doors with lock and low back panel in open grain. Lacquered bookcase top.

	DIMENSIONS (MM.)	CODE	UNITS	PKG	KG	M³	
	930 x 400 x 550 open grain bookcase	G301EM1	x 3	1	33,0	0,110	
				3	99,0	0,330	
	930 x 20 x 547 open grain doors with lock	G335CEM1	x 3	1	9,0	0,030	
				3	27,0	0,090	
	2790 x 425 x 41 laquered bookcase top	G606L01	x 1	1	27,2	0,160	
	2880 x 465 x 850 open grain back panel	F516EM1	x 1	3	82,5	0,222	
				TOTAL:	10	235,7	0,802

L 2880 A 465 H 2020/12 Pkg, 453,2 Kg, 2,580 m³

Three body sideboard with three pairs of lacquered doors and high back panel plus two decorative shelves. All in Espresso matt finish and open grain. Lacquered bookcase top.



	DIMENSIONS (MM.)	CODE	UNITS	PKG	KG	M ³
	930 x 400 x 550 open grain bookcase	G301EM1	x 3	1	33,0	0,110
				3	99,0	0,330
	930 x 20 x 547 open grain doors without lock	G335SEM1	x 3	1	9,0	0,030
				3	27,0	0,090
	2790 x 425 x 41 laquered bookcase top	G606L01	x 1	1	27,2	0,160
	2880 x 465 x 2020 open grain back panel	F536EM1	x 1	5	300,0	2,000
TOTAL:				12	453,2	2,580



Decorative shelves. Do not place more than 40 Kg in each shelf. For heavier loads the back panel should be reinforced with additional ironworks. Consult with your sales agent.

WARDROBE + FRIDGE



L 1015 A 500 H 2020 / 9 Pkg, 200,4 Kg, 0,850 m³

One body wardrobe divided into closet compartment with bar and shelf
compartment with mirror and integrated lighting + fridge.

	DIMENSIONS (MM.)	CODE	PKG	KG	M ³
	1015 x 500 x 2020	F344	8	187,4	0,700
	fridge	NEV1003	1	13,0	0,150
TOTAL:			9	200,4	0,850

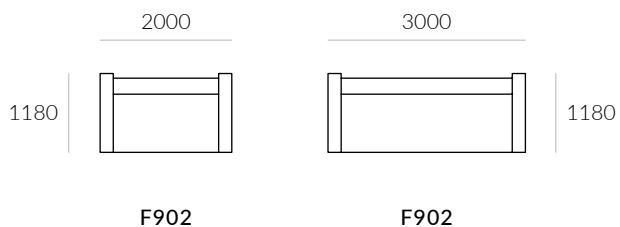
**F902 - L 2000 A 900 H 1180**6 Pkg, 226,2 Kg, 1,180 m³**F903 - L 3000 A 900 H 1180**6 Pkg, 300 Kg, 2,000 m³

Counter with sintered porcelain Neolith countertop in two different colors and wood structure.

DIMENSIONS (MM.)	CODE	PKG	KG	M ³
------------------	------	-----	----	----------------

COUNTERS

2000 x 900 x 1180

F902

6 226,2 1,180



3000 x 900 x 1180

F903

6 300,0 2,000



2000 x 900 x 1180

F912

6 226,2 1,180



3000 x 900 x 1180

F913

6 300,0 2,000

ofifran

Within Ofifran Group, Operational Excellence means increasing our customer's satisfaction, our market position and financial results by ensuring continual quality and cost improvement in our processes, products and services. Deployment of Operational Excellence enables us to meet the commitments within our Quality Policy.

Dentro del Grupo Ofifran, la excelencia en nuestras operaciones significa aumentar la satisfacción de nuestros clientes, nuestra posición en el mercado así como los resultados económicos, mediante la garantía de una mejora continua en la calidad y coste de nuestros procesos, productos y servicios. El despliegue de esta excelencia operacional nos permite satisfacer los compromisos de nuestra Política de Calidad.

Dans le groupe Ofifran, l'excellence dans nos opérations signifie augmenter la satisfaction de nos clients, notre positionnement dans le marché et aussi les résultats économiques, par la garantie d'un amélioration continu de la qualité et des coûts de nos procédés, produits et services. L'ensemble de moyens de cette excellence opérationnelle nous permet de satisfaire les engagements de notre Politique de Qualité.

В своей деятельности группа Ofifran стремится соответствовать требованиям клиента, а также быть конкурентоспособной, гарантируя улучшение соотношения цена-качество самого производства и услуг. Таким образом, деятельность группы Ofifran позволяет выполнять обязательства по качеству нашей продукции.



UNE EN 14073-2:05
UNE EN 14073-3:05
UNE 14074:05

Certificado de Sistema de Gestión de la Calidad



Kaizen Auditoría y Certificación (Certifica que el sistema de gestión de la organización)

OFIFRAN, S.L.

No está auditado y es conforme con los requisitos de la norma:

ISO 9001:2015

Sistema de gestión de la calidad. Requisitos

Para las siguientes actividades:

Diseño, fabricación y comercialización de mobiliario de oficina

Que se realizan en:

C/ Milla, 21. Pol. Ind. Gütemberg
46182 - Pobl de Valbuena
Valencia | España

Nº certificado: NA19.0013C

Fecha de renovación: 18 de octubre de 2019
Fecha de expiración: 17 de octubre de 2022

Miguel Ángel Chueca Tolosa
Miguel Ángel Chueca Tolosa
Comisión de certificación



Este certificado otorgado en el momento de aprobarse el presente certificado de conformidad de conformidad con el sistema de gestión de calidad.
KAIZEN CERTIFICACION, S.L. | C/ Leandra de Santiago, 4 - 7 VALBUENA
certificacion@kaizen-certificacion.com | www.kaizen-certificacion.com

Certificado de Sistema de Gestión Ambiental.



Kaizen Auditoría y Certificación (Certifica que el sistema de gestión de la organización)

OFIFRAN, S.L.

No está auditado y es conforme con los requisitos de la norma:

ISO 14001:2015

Sistema de gestión ambiental. Requisitos con orientación para su uso

Para las siguientes actividades:

Diseño, fabricación y comercialización de mobiliario de oficina

Que se realizan en:

C/ Milla, 21. Pol. Ind. Gütemberg
46182 - Pobl de Valbuena
Valencia | España

Nº certificado: NA19.0014M

Fecha de renovación: 18 de octubre de 2019
Fecha de expiración: 17 de octubre de 2022

Miguel Ángel Chueca Tolosa
Miguel Ángel Chueca Tolosa
Comisión de certificación



Este certificado otorgado en el momento de aprobarse el presente certificado de conformidad de conformidad con el sistema de gestión de calidad.
KAIZEN CERTIFICACION, S.L. | C/ Leandra de Santiago, 4 - 7 VALBUENA
certificacion@kaizen-certificacion.com | www.kaizen-certificacion.com

Certificado de Sistema de Gestión de Ecodiseño.



Kaizen Auditoría y Certificación (Certifica que el sistema de gestión de la organización)

OFIFRAN, S.L.

No está auditado y es conforme con los requisitos de la norma:

ISO 14006:2011

Sistema de gestión ambiental. Directrices para la incorporación del Ecodiseño

Para las siguientes actividades:

Diseño, fabricación y comercialización de mobiliario de oficina

Que se realizan en:

C/ Milla, 21. Pol. Ind. Gütemberg
46182 - Pobl de Valbuena
Valencia | España

Nº certificado: NA19.0015D

Fecha de renovación: 18 de octubre de 2019
Fecha de expiración: 17 de octubre de 2022

Miguel Ángel Chueca Tolosa
Miguel Ángel Chueca Tolosa
Comisión de certificación



Este certificado otorgado en el momento de aprobarse el presente certificado de conformidad de conformidad con el sistema de gestión de calidad.
KAIZEN CERTIFICACION, S.L. | C/ Leandra de Santiago, 4 - 7 VALBUENA
certificacion@kaizen-certificacion.com | www.kaizen-certificacion.com

Anexo al Certificado del Sistema de Gestión de Ecodiseño.



Anexo Número del certificado: NA19.0015D
(ISO14006:2011) de la empresa:

OFIFRAN, S.L.

Para las siguientes incorporaciones de productos:

OFICE (SOFIA, PIVOLANCE (SERA), COMANDO FREE, ELEMENTOS COMANDO);
DIRECCIONAL (GALLERY, FREESTOP, SILESA, COMANDO, SERRINA);
CLASSIC (SOFI (SOFI), SERRIN (SERRIN));
SEATING (SOFAS PIVOL, ADVANCE, EAST, RAY, CINCOVENTI, BANDEL SQUARE,
SOFAS GALLERY, KJEL, CLASSIC, CHESTER, BORDO);

Miguel Ángel Chueca Tolosa
Miguel Ángel Chueca Tolosa
Comisión de certificación



Este anexo es un anexo a un certificado de conformidad de la norma ISO14006:2011 de 2019 (ISO 14006:2011) de conformidad con el sistema de gestión de calidad de conformidad con el sistema de gestión de calidad.
KAIZEN CERTIFICACION, S.L. | C/ Leandra de Santiago, 4 - 7 VALBUENA
certificacion@kaizen-certificacion.com | www.kaizen-certificacion.com

ofifran